

UTRF-168 Component and Hardware List

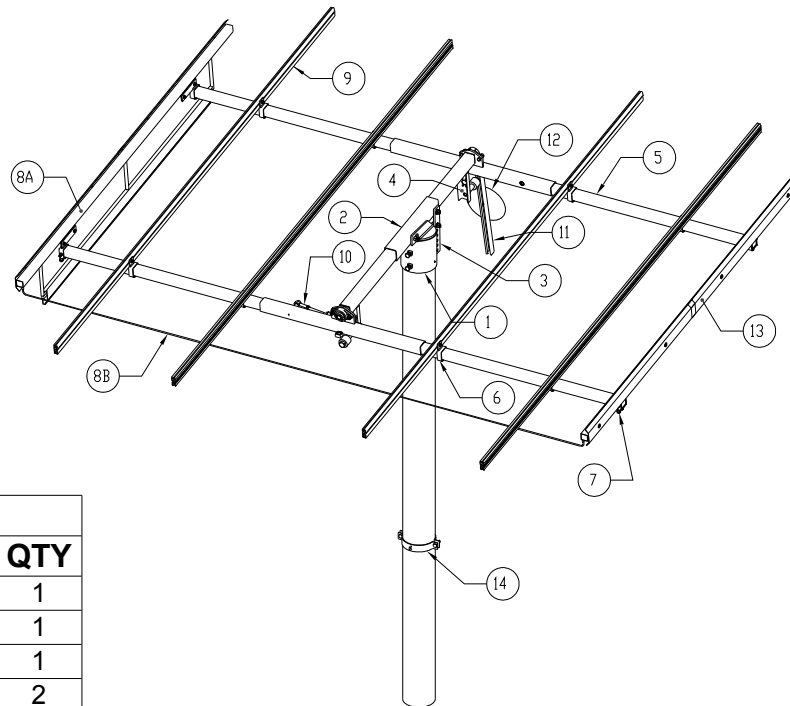

Components		
Part #	Description	QTY
1	Gimbal	1
2	Axle Tube	1
3	Seasonal Adj. Bar	1
4	Shock Mounting Arm	2
5	Truss Tube	2
6	Rail Slider	8-12
7	Canister Slider	4
8A	Canister Set	1
8B	Transfer Tube	1
9	Mounting Rail	4-6
10	Cylinder	1
11	Counterweight Arm	1
12	25lb Counterweight	1
13	Shadow Plates	4
14	Storm Collar	1

<u>Component</u>	<u>Hardware Description</u>	<u>QTY</u>	<u>Location</u>
-------------------------	------------------------------------	-------------------	------------------------

Gimbal	3/4" x 2" Hex Bolt	2	On Gimbal
	3/4" x 6" Hex Bolt	1	On Gimbal
	3/4" Flat Washer	1	On Gimbal
	3/4" Hex Nut	1	On Gimbal
	3/4" Jam Nut	1	On Gimbal
	3/8" x 11" Carriage Bolt	1	Hardware Bag
Seasonal Adj. Bar	3/8" Hex Nut	2	Hardware Bag
	5/8" x 5" Hex Bolt	1	On Seasonal Bar
	5/8" x 2" Hex Bolt	1	On Seasonal Bar
	5/8" Flat Washer	2	On Seasonal Bar
	5/8" Spring Lock Washer	2	On Seasonal Bar
	5/8" Hex Nut	2	On Seasonal Bar

<u>Component</u>	<u>Hardware Description</u>	<u>QTY</u>	<u>Location</u>
Bearing Block	3/8" x 1" Hex Bolt	4	On Axle
	3/8" Spring Lock Washer	4	On Axle
Locking Bar	3/4" x 3-1/2" Hex Bolt	1	On Locking Bar
	3/4" x 2-3/4" Hex Bolt	1	On Locking Bar
	1" (diameter) x 2-3/8" Spacer	1	On Locking Bar
	3/4" Hex Nut	2	On Locking Bar
	3/4" Spring Lock Washer	2	On Locking Bar
Shock Hardware	3/4" Rod End	1	On Shock
	3/4" Jam Nut	1	On Shock
	1" (diameter) x 1-1/2" Spacer	1	Hardware Bag
	0.5 mL Tube of Loctite - #242	1	Hardware Bag
Bumper Bolt	1" x 6" Hex Bolt	2	On Axle
	1" Jam Nut	2	On Axle
	EPDM Rubber Bumper	2	On Axle
	1-1/4" (dia) x 2-1/2" Spacer	1	On Axle
Storm Collar	1/2" x 2-1/2" Round Head Bolt	2	Hardware Bag
	1/2" Hex Nut	2	Hardware Bag
	1/2" Spring Lock Washer	2	Hardware Bag
Rail Slider (qty. varies with rail configuration)	3/8" x 1" Round Head Bolt	8-12	On Slider
	3/8" x 1-1/4" Hex Bolt	8-12	On Slider
	3/8" Flat Washer	8-12	On Slider
	3/8" Nylock Nut	8-12	On Slider
	3/8" Jam Nut	8-12	On Slider
Canister Slider	3/8" x 1-1/4" Hex Bolt	8	On Slider
	3/8" x 1" Hex Bolt	8	On Slider
	3/8" Flat Washer	16	On Slider
	3/8" Nylock Nut	8	On Slider
	3/8" Jam Nut	8	On Slider
Truss Tube / Axle	Cast Iron Flange Bearings	2	On Truss Tube
	9/16" x 2" Hex Bolt	4	On Truss Tube
	9/16" Spring Lock Washer	4	On Truss Tube
	9/16" Hex Nut	4	On Truss Tube
	1-1/4" Brass Spacer	1	On Axle
	5/32" Allen Wrench	1	Hardware Bag
Counterweight Arm	1/2" x 2" Hex Bolt	1	On #25 Weight
	1/2" Flat Washer	2	On #25 Weight
	1/2" Lock Washer	1	On #25 Weight
	1/2" Hex Nut	1	On #25 Weight
	3/4" Plastic Spacer	1	On #25 Weight
	1" Jam Nut	1	On Arm
Shadow Plate	1/4" x 3/8" Round Head Screw	8	Hardware Bag
	1/4" Fender Washer	8	Hardware Bag
	1/4" Spring Lock Washer	8	Hardware Bag
Module Hardware (per module) & Misc.	1/4" x 5/8" Hex Bolt	4	Hardware Bag
	1/4" (Stainless) Flange Nut	4	Hardware Bag
	Rubberized Cable Clamps	2	Hardware Bag
Offset Bracket Kit (only w/ extra rails)	3/8" x 1-1/4" Hex Bolt	4	On Bracket
	3/8" Flat Washer	8	On Bracket
	3/8" Nylock Nut	4	On Bracket