

ZOMEWORKS

CORPORATION

UTRF-168 Track Rack™

Assembly Instructions

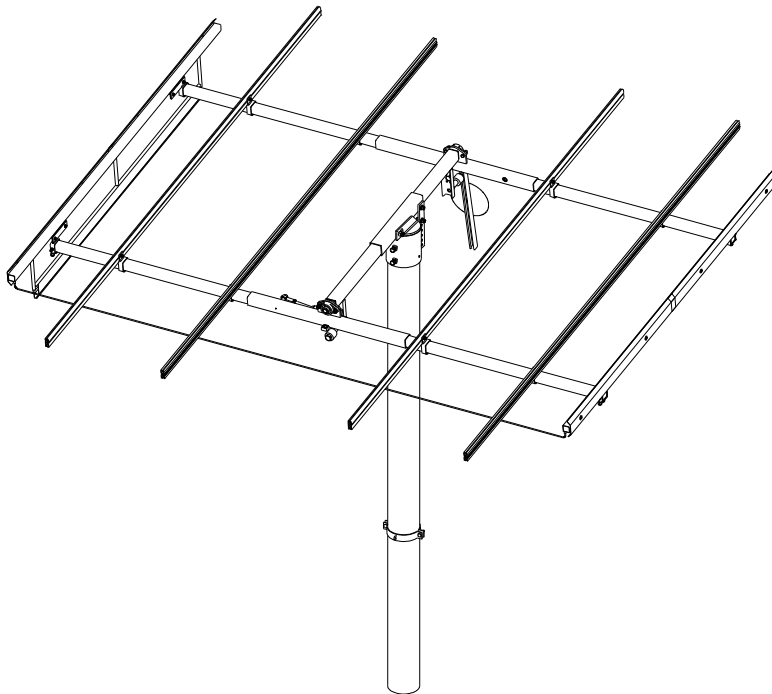

1011A Sawmill Road NW, PO Box 25805, Albuquerque, NM 87125 USA
(505) 242-5354 / (800) 279-6342 / FAX (505) 243-5187
E-mail: zomework@zomeworks.com

Thanks!

Thank you for your purchase of a Zomeworks Track Rack™. The Zomeworks Track Rack is an ingenious and economical way to increase the annual output of photovoltaic modules by an average of 25% over those mounted on a fixed array.

Tracker Operation

The Track Rack™ changes its orientation to the sun by shifting a mass of refrigerant between canisters on the east and west sides through a copper tube located at the southern-most end of the canisters. Aluminum “shadow plates” vary the amount of sunlight hitting both canisters. When the rack is not directly facing the sun, the canister farther from the sun absorbs more heat and builds pressure. This forces the fluid to move to the other canister, resulting in movement of the rack. Tracking is the result of a constant search for equilibrium. This process is effective throughout a very wide temperature range, and works well even in hazy and intermittent light conditions.

Choosing A Location

Choose a location where the tracker will receive clear, unobstructed light throughout the day. Keep in mind that the Sun rises and sets north of east and west in the summer, and rises and sets south of east and west in the winter. It is particularly important that your Track Rack™ receive morning light that is unshaded by structures, trees, bushes, etc. As the rack starts the day facing west (the position as of the previous sunset), clear morning light is required to “flip” the rack to the east. Morning shadows will delay wake-up time.

Trackers and Wind

The Cylinder is the first line of defense for the Track Rack™ against wind. It prevents sudden gusts from pushing the rack off-course, as well as restricting any violent movement that may harm the rack and modules. The Cylinder yields to a constant force by design, thus promoting tracking and, as a result, will be affected in a constant wind-loading situation. The bumper bolts are the second failsafe in the structure. They prevent catastrophic failure from occurring by limiting the overall travel of the Track Rack™.

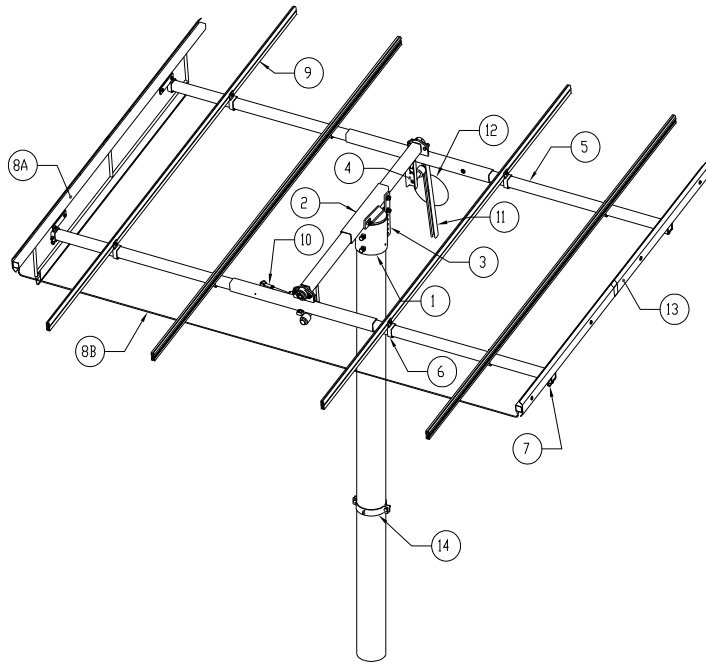

Part Names

- 1) Gimbal
- 2) Axle Tube
- 3) Seasonal Adj. Bar
- 4) Cylinder Mounting Arm
- 5) Truss Tube
- 6) Rail Slider
- 7) Canister Slider
- 8A) Canister Set
- 8B) Transfer Tube
- 9) Mounting Rail
- 10) Cylinder
- 11) Counterweight Arm
- 12) 25 lb Counterweight
- 13) Shadow Plates
- 14) Storm Collar

Recommended Tools:

- (2ea) 1-1/8", 15/16", 3/4", 9/16", and 7/16" Open-End Wrenches
- 1-1/8" Socket and Wrench
- Tape Measure
- Rubber Mallet (to protect finish)
- 15' Rope (medium weight)
- Permanent Marker
- 5/32" Allen Wrench (provided)
- Ratchet Straps for Storm Collar (or similar)
- Four Sawhorses (not required, but very useful)
- (2ea) 10' Stepladders

Pole Installation

Zomeworks can only provide general guidelines for the design and installation of the mounting pole. Our recommended hole diameters and depths are based on "typical soils". For installations in sandy or muddy areas, for tall mounting poles, or for any situation different than what is described in these instructions, you should consult a local structural engineer. Large trackers can receive very high wind loads – so a sufficiently strong pole and foundation is crucial. The height of the pole must provide adequate ground clearance for the rack and mounted modules. Zomeworks can provide assistance for spacing multiple racks to avoid shading.

NOTE: ZOMEWORKS CORPORATION ASSUMES NO LIABILITY FOR THE STRUCTURAL INTEGRITY OF THE POLE AND ITS INSTALLATION. SOIL AND WIND CONDITIONS VARY. IF THERE IS ANY DOUBT, CONSULT WITH A LOCAL STRUCTURAL ENGINEER. TALK TO YOUR CERTIFYING ENGINEER BEFORE THE POLE IS INSTALLED!

- The correct pipe (to be provided by customer) is as follows:

| | |
|----------|--------------------------|
| UTRF-168 | Schedule 40 – 8" nominal |
|----------|--------------------------|

- Heavier steel pipe (sch 80 or sch 120) can be used as long as outer diameter is 8.625”.
- Using the chart provided below, find the **MINIMUM** acceptable pole height above your finished grade. The suggested pole heights will provide approximately 3’ of ground clearance with the largest module arrays installed. It is strongly recommended that the pole height meet our minimum specifications.
- The **MINIMUM** recommended hole depth is 1/3 the total length of the pole – 1/3 in the ground, 2/3 above the ground.

For example: 10' above grade, 5' below grade – 15' total length.

- Center pipe in hole, use a level or plumb line to insure pipe is vertical.
- Fill the hole with concrete (3000 psi minimum strength), and recheck verticality.
- The pipe may be filled with concrete for added strength.
- Allow concrete and pipe to set for a **MINIMUM** of 36 hours before installing Track Rack™.

| MOUNTING POLE RECOMMENDATIONS | | | | | | |
|--|--------------------|---------------------|----------------------|----------------------|----------------------|----------------------|
| Model | UTR-020 | UTRK-040 | UTRF-072 | UTRF-090 | UTRF-120 | UTRF-168 |
| Sch 40 Steel Pipe (A) | 2 1/2" (3" OD) | 3" (3 1/2" OD) | 6" (6 5/8" OD) | 6" (6 5/8" OD) | 6" (6 5/8" OD) | 8" (8 5/8" OD) |
| Minimum Pole Height (B) | 76" | 84" | 96" | 108" | 120" | 144" |
| Minimum Pole Depth (C) | 38" | 42" | 48" | 54" | 60" | 72" |
| Ground Clearance at 45° Tilt | 36" | 23" | 28" | 21" | 24" | 26" |
| Minimum Hole Diameter (D) | 18"Ø | 18"Ø | 24"Ø | 24"Ø | 24"Ø | 30"Ø |
| Maximum Rack Dimensions (as viewed from above) | 67" E-W 44" N-S | 124" E-W 48" N-S | 124" E-W 110" N-S | 146" E-W 140" N-S | 146" E-W 160" N-S | 172" E-W 206" N-S |
| Capacity (Module Area) | 20 ft² | 40 ft² | 72 ft² | 90 ft² | 120 ft² | 168 ft² |

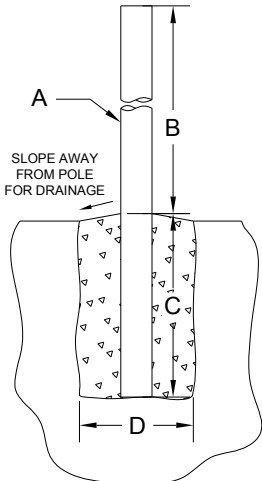

Rack Assembly Instructions

Decide on a Strategy

The easiest and quickest way to install a rack is to build it at ground-level on saw horses and lift the completed rack in to place on the pole with a lift, small crane, or similar. The alignment of rack components is much easier to achieve this way. However, for the purpose of these instructions, it is assumed that the rack will be built in-place on the pole.

Attaching Gimbal to Pole

- Place Gimbal on top of pole.
- Orient Gimbal so that 3/4" x 2" bolts are facing **true south** (adjust for magnetic declination)
- Tighten bolts to 75-100 ft-lbs torque in turns to insure both are tight.

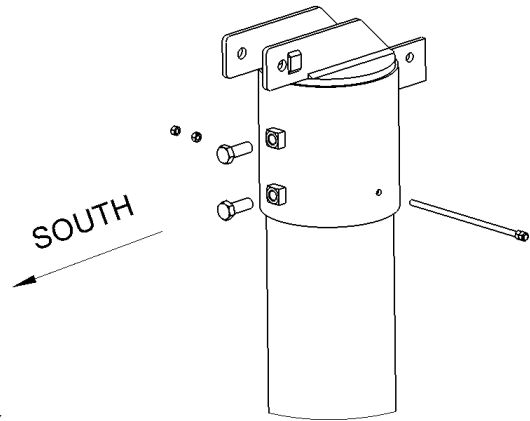

3/8" x 11" CARRIAGE BOLT CAN BE INSTALLED TO PROVIDE ADDITIONAL RESISTANCE TO UPLIFT AND TWIST. THIS MAY ALSO BE A REQUIREMENT OF THE PERMITTING AUTHORITY.

- With Gimbal oriented properly (set bolts pointed true south), use pre-drilled 7/16" holes as a guide to drill through the pipe on both sides.
- Slide the bolt through the Gimbal and pipe, use two 3/8" hex nuts to fix it in place.

Attaching Axle to Gimbal

- Orient the Axle so that the Cylinder Mounting Arm(s) are hanging below.
- Align the center hole (3/4") of the Axle with the holes on the Gimbal tabs.
- Insert the 3/4" x 6" hex bolt on the same side as the small welded tab (see diagram).
- The full size 3/4" hex nut goes on first, followed by the 3/4" jam nut (thinner).
- For the purpose of assembly, it is only necessary to tighten the nuts lightly.
- When the rack is fully assembled, **the hex nut must be tightened to approximately 100-120 ft-lbs.**
- After tightening the hex nut, use a second wrench to tighten the two nuts together.

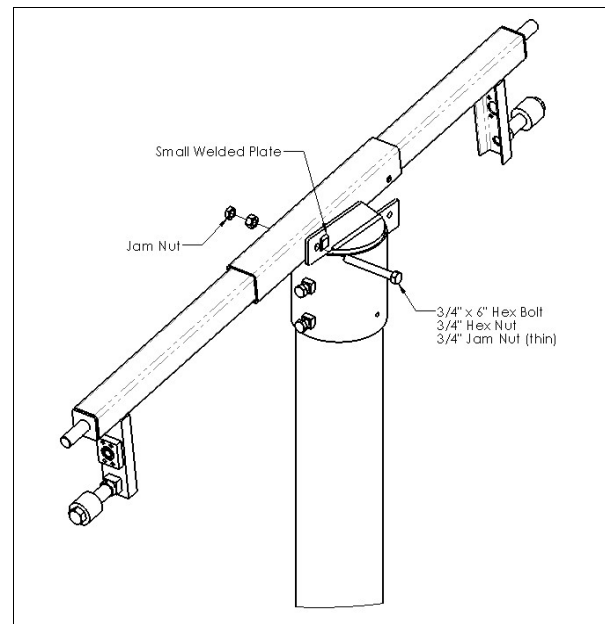

Installing Seasonal Adjustment Arm

- Bolt Seasonal Adjustment Arm to Axle and Gimbal as shown.
- Notice holes are offset to one side – the “thin” edge faces the Gimbal.
- For the purpose of installing subsequent components, set axle to 7.5 degree tilt.
- After final assembly and adjustment, tighten bolts to 75 ft-lbs.

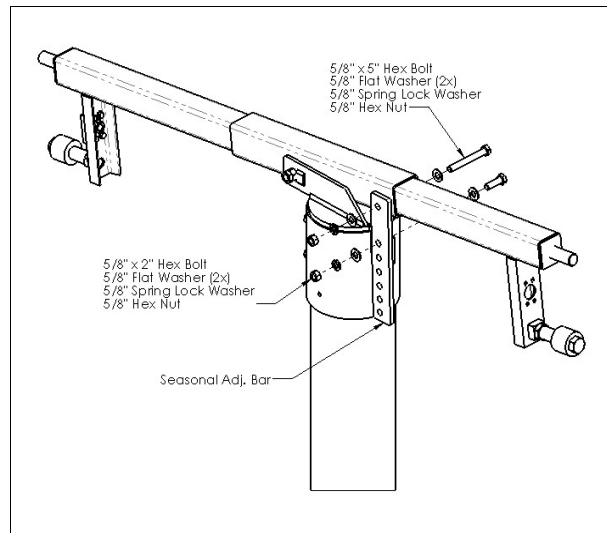
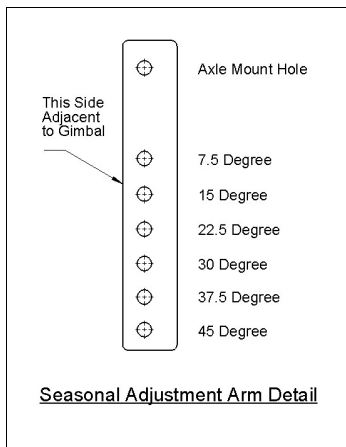

Installing Truss Tubes

- Using 5/32" Allen wrench provided, make sure that the set screws on each Truss Tube bearing are backed out.
- **Install Brass Spacer on north end of axle (if not already installed).** This spacer prevents the Truss Tube from eventually making contact with the end plate of the Axle, which will inhibit tracking.
- Slide Truss Tube on to the north end of the Axle until the bearing is snug against the bushing and axle end cap. Tighten set screws.
- Refer to the module layout drawing in the instruction packet. The important dimension is the center-to-center distance between the two Truss Tubes.

| | |
|----------|---------|
| UTRF-168 | 74 3/4" |
|----------|---------|

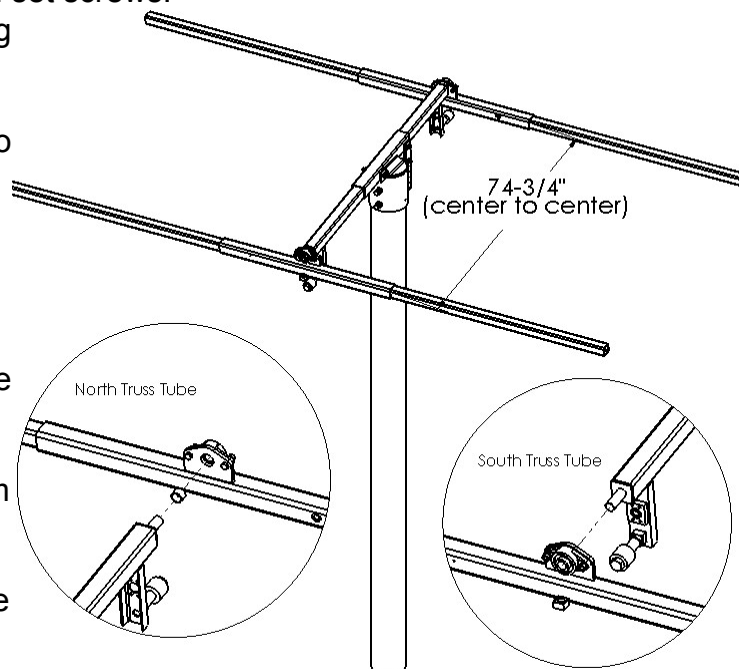

- Slide second Truss Tube on to the south end of the Axle. Using a tape measure, space the southern Truss Tube so that the center-to-center distance (as measured from the square tube sections) is correct. Tighten set screws. Adjustments may need to be made when installing subsequent components.
- **Note:** The correct orientation of the Truss Tubes is with the square tube hanging below the Axle and the bearings facing away from each other.
- **Note:** At this point the Truss Tubes may be quite a bit out of alignment. This is because the bearings are designed to "swivel" in their housing. This feature allows the bearings to tolerate misalignment and also prevents flex in the rack from damaging the bearings.

Pre-Installing Sliders

- Depending on the specific configuration of your rack, it will come with different sizes and quantities of Sliders. The two types of Sliders are shown below.
- Some rack configurations may include a set of Extruded Rail-type Sliders that are designed to mount on the reinforced midsection of the Truss Tube. The square tube section of these sliders is noticeably wider.
- If your rack comes with the wider Extruded Rail Sliders, install those first. The correct orientation is with the tab on the top side of the Truss Tube. The included drawing *may* specify whether the tab should be on the left or right side. If this is the case, install as directed. If not, the orientation is not critical.
- Next, install any regular-size Extruded Rail Sliders.
- Finally, install the four Canister Sliders so that the outside edges are flush with the ends of the Truss Tube. **The correct orientation on the UTRF-168 is with the tabs on the top side and the overhanging section of the tabs facing towards the middle of the rack.** See drawing.
- Bolts should be tight enough to clamp securely on to the Truss Tube without crushing the square tube wall.
- With bolts adequately pre-loaded, tighten jam nuts.
- Extruded Rail Sliders will be aligned and tightened in a later step.

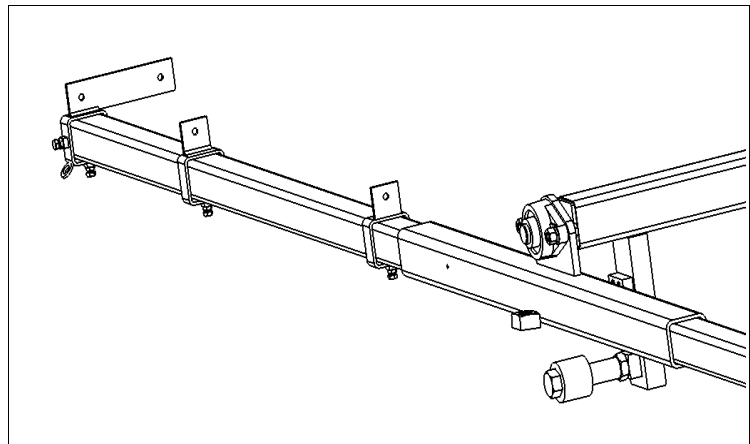
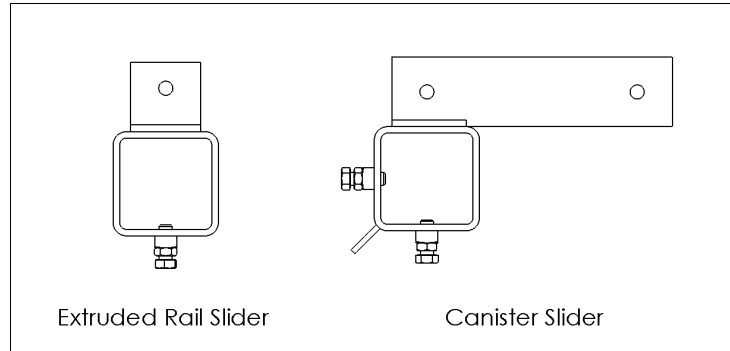

Canister Installation

- **Important Note: Fluid is driven between canisters via 1/4" copper tube. When removing the Canister Set from the package and when straightening the transfer tube, be careful to not crimp it. We recommend that at least two people handle the canisters to prevent any damage.**
- Orient the Canister Set so that the unit with the wake-up fin is on the west side of the rack (with the wake-up fin underneath the rack). The transfer tube is designed to enter from the bottom (underside) of each canister. Bolt the Canister Set to the Canister Sliders with the 3/8" hardware provided. See drawing below.

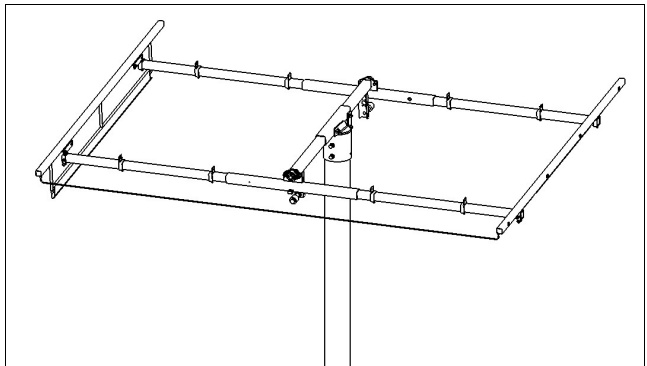

- Before fully tightening bolts, align the rack visually to remove any twist by measuring across the diagonals as shown. This will make the rails and modules easier to install.
- With rack aligned, tighten bolts.

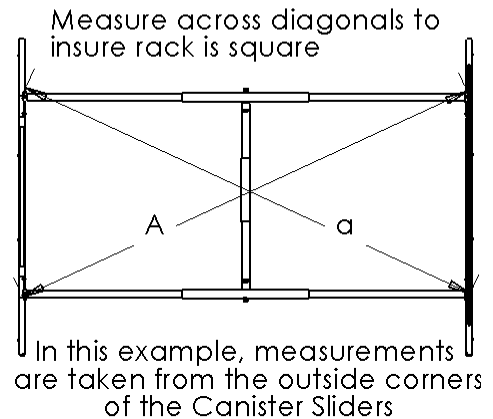
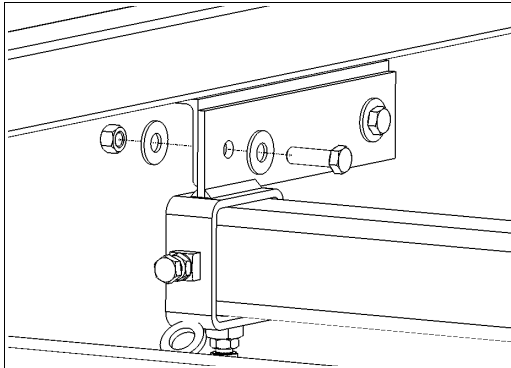

When $A=a$, rack is squared

Extruded Mounting Rail Installation

- Description: The Zomeworks Extruded Rail is designed to be mounted to the sliders using 3/8" round-head, square-neck bolts. The edges of the extrusion are different – one side has a slot to accommodate standard 1/4" hex bolts and the other 5/16" hex bolts (see diagram at right). When installing rails on to the Truss Tube pay attention to this orientation!

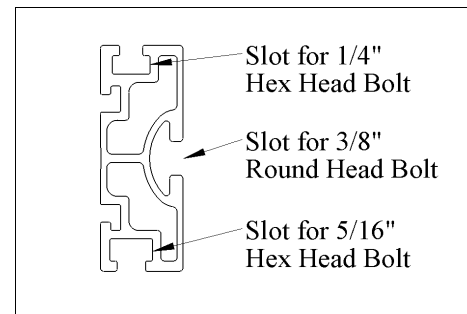

*- Zomeworks only provides 1/4" hardware for modules. For specific modules, 5/16" hardware can be supplied by the customer / installer.

- In order to mount the Extruded Rails in the correct spot, use a permanent marker to layout the position of the Rail Sliders. This can be done a couple of ways:

Method 1: Find the center of the Extruded Rail. Mark lines the "Half Distance" away on both sides of center. Refer to the table below to find the correct distance. These marks will coincide with the centerline spacing of the Truss Tubes.

| Rack Model | Truss Tube Spacing | Half Distance |
|------------|--------------------|---------------|
| UTRF-168 | 74 3/4" | 37 3/8" |

Method 2: Take a look at the layout drawing provided in the instruction packet. There is a dimension showing the distance from the cut end of the Extruded Rail to the centerline location of the Rail Slider. With the Extruded Rail in the correct orientation – the 3/8" slot facing the outside edge of the Rail Slider, and either the 1/4" or 5/16" slot on top (depending on hardware used) – mark a line.

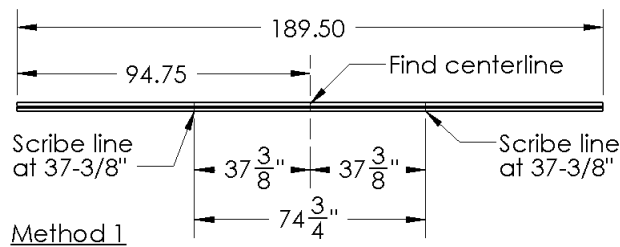

Pre-Installing Mounting Hardware

- Now that the Extruded Rails have been marked, slide the provided module mounting hardware (1/4" or 5/16" x 5/8" hex bolts) into the tracks at the approximate mounting locations. It is only necessary to locate the bolts in the general area of the module frame holes – this will make the installation of the modules easier. Also slide two 3/8" round head bolts to the center of the marked lines.

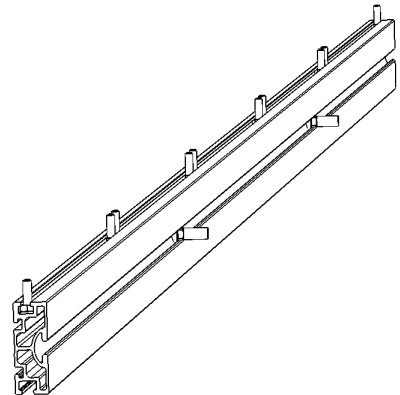

Installing Rails on Truss Tubes

- Using the marked lines as a guide, align the Extruded Rail to the Rail Sliders. Install one flat washer and Nylock nut. Loosely tighten the nut.
- In the process of installing the rails, use a measuring tape to verify that the rails are square and parallel with the rack.

Installing Modules

- Refer to the Module Layout Drawing provided in the instruction packet.
- Landscape orientation:** The first module should be installed flush with the edge of of the rail.
- Portrait orientation:** The module mounting hole / hex bolt should be located 1" from the end of the rail.
- Make any required adjustments to get the hex bolts lined up with the module mounting holes before installing the hex nut. Once the module is in place, tighten backing nut to no more than 75 **in-lb** (6.25 ft-lb) torque. When installing subsequent modules, refer to the layout drawing for the correct spacing between modules, this is usually 1/2".
- When all modules have been installed, verify that everything is square and the modules are equidistant from the center axle. Tighten hardware if necessary.
- Use the two cable clamps provided to route the copper transfer tube along the backside of the modules.

Locking Bar

- The Locking Bar is a 17-1/2" long piece of 2" x 2" x 1/4" steel angle (with bolts) that can be used to immobilize the rack in anticipation of high-wind events or if the rack needs to be fixed in place.
- The Locking Bar takes the place of the Cylinder.
- The 3/4" x 2-3/4" Hex Bolt is first secured to the Bearing Block with a Hex Nut. The Locking Bar is then tightened against the first Hex Nut.
- Install as shown.

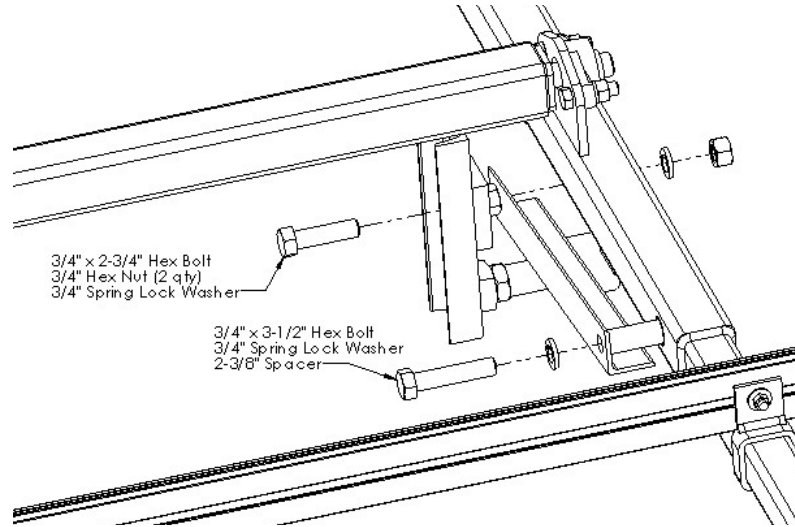

Cylinder Installation

- Coat the ends (about an 3/4" inch) of the 3/4" threaded stud and the 3/4" x 3-1/2" bolt with the Loctite® #271 provided.
- First install the threaded stud in to the spherical bearing. The stud is secured with a 3/4" Hex Nut. It is not necessary to fully tighten yet.
- **Note:** The Cylinder is very stiff. It will be necessary to rotate the rack to locate the mounting hole for the rod end.
- After aligning the rod end with the threaded insert, install the 3/4" x 3-1/2" Hex Bolt through the rod end, flat washer and 1-1/2" long spacer.
- Tighten the hex nut on the threaded stud (best accomplished using a 1-1/8" socket) and the hex bolt securing the rod end to 125 ft-lbs. A medium-sized adjustable wrench or pliers is not sufficient for this amount of torque.
- This is high-stress connection and should be checked periodically.

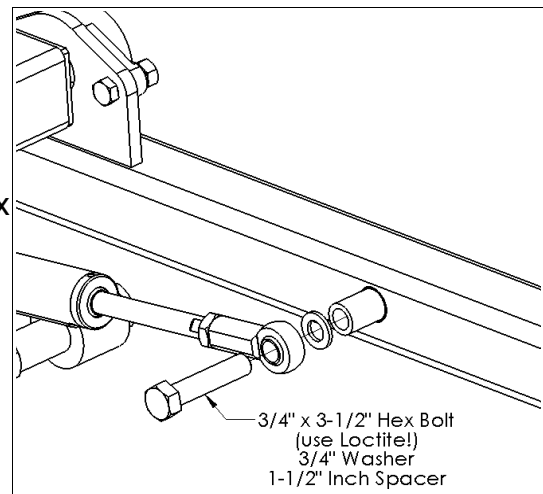
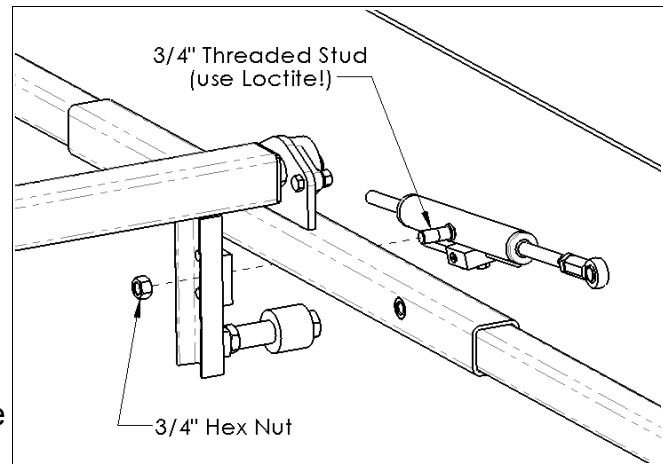

Installation of the Counterweight

- The Counterweight assembly bolts to the 1" square nut welded on the north-end Truss Tube, directly underneath the bearing.
- Making sure the 1" all-thread rod is fully engaged with the threads of the square nut, turn the Unistrut® so that the open face is pointing towards the mounting pole.
- Tighten jam nut firmly.
- The 25-pound weight should be installed at a point approximately 2/3 the way down the Unistrut®. Fine adjustments are best made after monitoring the performance of the rack.
- See diagram for placement of hardware.

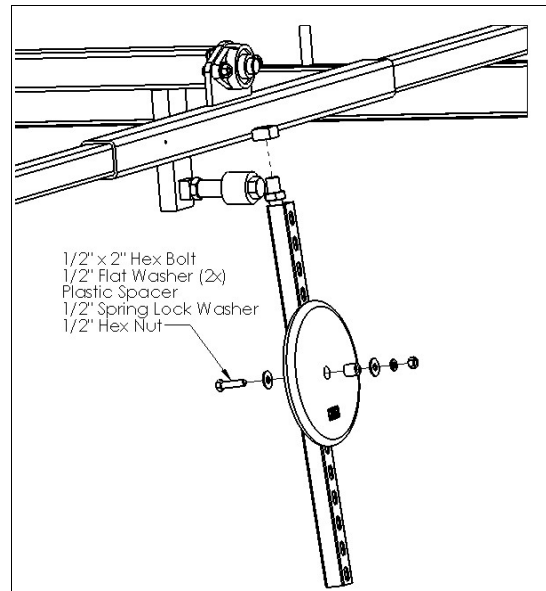

Installing Shadow Plates

- Shadow Plates come in four pieces. The plate that has a Zomeworks sticker is designed to be installed on the NE corner of the rack.
- Install the Shadow Plates so that the ends of the plates are even with the ends of the Canisters and they overlap by approximately 2" in the middle.
- Using the 1/4" round-head bolts, lock washers, and wide flat washers provided, install as shown.

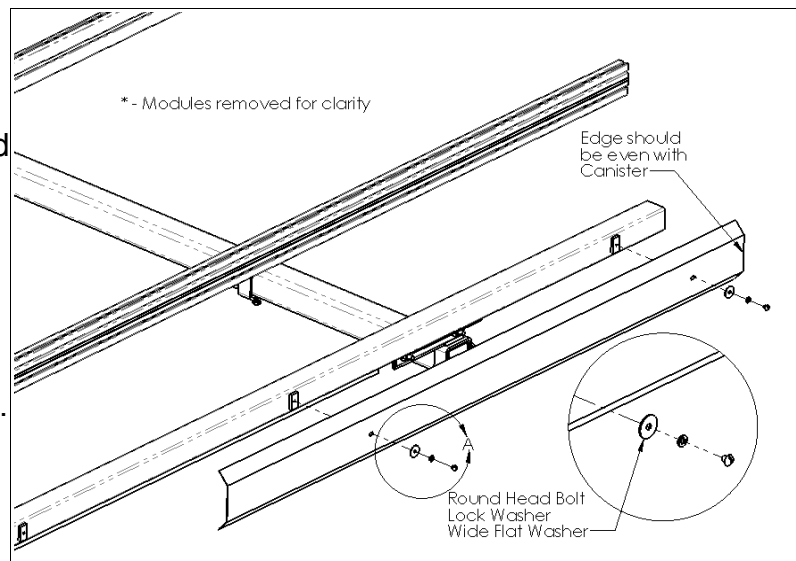

Installing Storm Collar

- The Storm Collar offers additional protection from high wind / storm events and can also be used when building or maintaining the rack. The collar is an anchor point for running ropes or ratchet straps (to be provided by the customer) from the four corners of the rack.
- The installation height of the Storm Collar is not critical – we recommend 36" to 48" above the ground level for easy access.

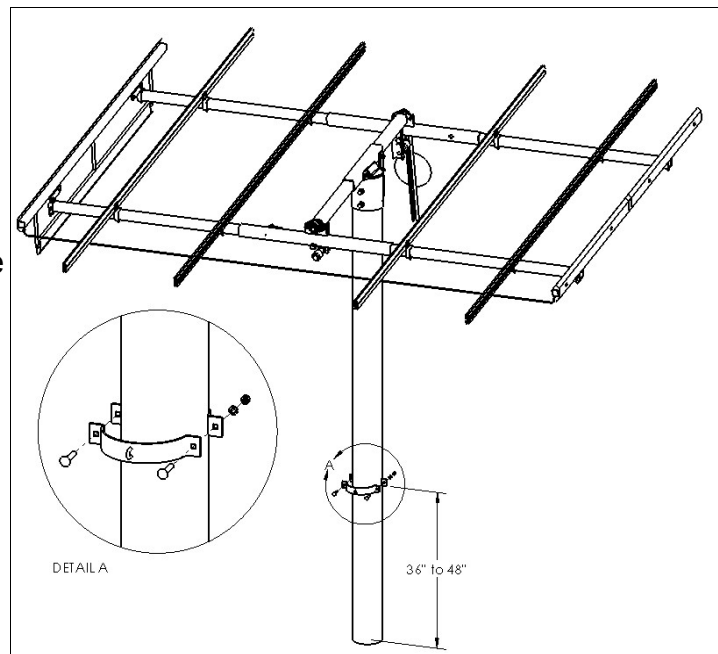

Balancing and Counterweight Adjustments

- Balancing and set-up is crucial to getting the most out of your Track Rack™
- Start by ensuring that the module rails are installed equidistant from the center axle.
- Pay attention to balance when installing additional components (inverters, wires / conduit, etc.)
- Track Racks™ will work within a range of Counterweight adjustments.
- If the tracker is not going through the full travel range, raise the Counterweight.
- Keeping the Counterweight low will make the tracker more stable in wind.
- Provided that additional stability is not required for gusty winds, the optimal Counterweight position results in the Truss Tube lightly touching the Bumper Bolt at the beginning and end of the day (when all Freon has been shifted).

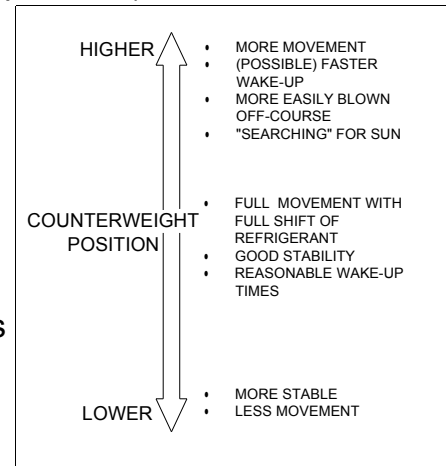

Seasonal Adjustments

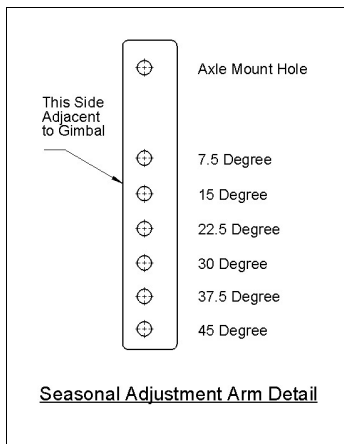

- Trackers can be tilted in one position or adjusted seasonally to increase output. Adjusting tilt throughout the year can add approximately 3% to the annual output (will vary with location, climate, etc).
- If setting the rack for one year-round setting, the tilt should be close to the latitude.

For example: In Albuquerque, NM (latitude 35.1° N) a tracker should be tilted close to 35° (as measured from horizontal). The Seasonal Adjustment Bar offers positions of 30° and 37.5° – either of these settings will work well.

- If adjusting the rack throughout the year, adjust the tilt so that the sun hits the surface of the modules as close to a right angle as possible.
- A good compromise is to adjust the rack to a tilt of latitude + 15° a month or so after the fall equinox (September 22th) and latitude – 15° a month or so after the spring equinox (March 20th).

Maintenance

- Bearings with grease zerks should be lubricated with a general-purpose bearing grease twice a year.
- Paint touch-up will be necessary to prevent rusting. Sand off all rust prior to painting. Use a high-quality enamel or Rustoleum® type paint.
- If the Track Rack™ is installed in a corrosive climate, check the axle and bearings frequently for rust or corrosion; you may need to grease the bearings 3 to 4 times per year and keep the axle coated with grease or a corrosion inhibitor.
- Check the hardware used to secure the Cylinder and Bumper Bolts twice a year and

tighten if necessary. Also check the Axle pivot bolt and Seasonal Adj. Bar bolts. Loose bolts increase wear on mating parts and introduce the potential for failure.

- Inspect the pivot bolt area of the Axle-Gimbal junction for wear. Signs of excessive movement may indicate that the bolt has worn down. Another indication of wear is that the bolt, even when tightened properly, repeatedly comes loose. If this is the case, replace the bolt.

PROPER MAINTENANCE IS THE RESPONSIBILITY OF THE CUSTOMER!

HIGH WINDS: Trackers should be tied in horizontal position if high-wind events are anticipated. The Storm Collar can be used in conjunction with tie-down straps or the Locking Bar can be used.

EXTREME COLD: In cold weather the fluid in the Cylinder becomes more viscous and can increase wake-up times. In very cold temperatures ($< -10\text{F}^\circ$), trackers may cease to track. In these conditions we recommend tying the tracker in a fixed due-south position at the steepest tilt angle.

F-Series Tracker Troubleshooting

- **TRACKER SITS LEVEL, LEANS TO ONE SIDE, OR DOES NOT MOVE**

1. Manually move tracker through its entire range of motion. Check for any mechanical interference, for example: wiring, tree branches, protruding bolts, etc. and correct if necessary.
2. Check Shadow Plates for proper installation. The tracker **will not** work without them.
3. Be sure the Track Rack™ is pointing south (in the Northern Hemisphere) and the copper transfer tube is mounted on the south (lower) end of the frame, and is not crimped in any way.
4. Check for any wiring that may stop the Track Rack™ from turning freely. Also check if wiring and junction boxes, etc. are balanced about center axle.
5. The Cylinder valve may be improperly adjusted. On a calm, sunny day disconnect the rod end at the Truss Tube. If it tracks without the Cylinder, call Zomeworks. **Warning: Do not leave rack unattended with Cylinder disconnected!**
6. The Track Rack™ moves when sunlight warms one canister which then forces liquid into the other canister. You may simulate the sunlight's effect by warming the lower canister with a hair dryer or carefully with a hand torch (alternately, the upper canister can be cooled with wet towels or water spray). Within 10 minutes the tracker should begin to rotate toward the cooler canister. If the tracker does not move, and you have checked the assembly for free movement, the Canisters may have lost their charge. Call Zomeworks tech support.

- **TRACKER IS SLOW TO WAKE UP**

1. Check that your tracker is getting full, early morning sun shining underneath the framework. The wake-up fin (under the west-side canister) must see the sun.
2. Check that modules and electrical components are balanced over the center axle.
3. Check that bearings are lubricated and move easily. **NOTE:** If the Track Rack™ is installed in a corrosive climate, check the axle and bearings frequently for rust / corrosion.

4. The Cylinder may have excessive resistance. This can be adjusted in the field. Call Zomeworks tech support for instructions.

- **TRACKER DOES NOT HIT THE BUMPER STOPS**

1. Trackers are very effective even if they don't track all the way to the bumper stop. The bumper stops are set for approximately 90° of rotation.
2. To increase the amount of rotation, raise the counterweight. **NOTE:** Raising the counterweight also makes the tracker slightly less stable in wind. For optimum tracking and stability, the Truss Tube should be only be resting lightly on the bumper bolt at the beginning and ending of the day. If the tracker rotates further to one side than the other, this may indicate that it is imbalanced left to right. This can be fixed by making small adjustments to the position of the mounting rails / modules.

- **GENERAL SUMMARY**

1. For proper performance, trackers must be assembled correctly.
2. The Track Rack™ should rotate smoothly throughout the entire range, with the only drag supplied by the Cylinder. If friction or interference is noted, check assembly against instructions and make required corrections.
3. Photovoltaic modules should be mounted as shown in the module layout diagram and as described in the instructions. Balance is critical!
4. There must be a minimum of 2" from the edge of the solar module to the Canister. Insufficient space will interfere with tracking.
5. The Track Rack™ must be in a location that maintains a clear line-of-sight to the sun throughout the day, and during different seasons. Shadows cast in the early-morning light can significantly delay the wake-up time.
6. If high winds or severe storms are expected, securing the rack in a horizontal position with straps is the best way to prevent damage.
7. **Zomeworks Track Racks™ will move in the wind, much as trees do. This motion is expected and does not harm the tracker or its performance. Unless a tracker is blown far off the sun and stays there, the output is hardly affected. Overall, Track Racks™ far exceed the performance of a fixed array.**

ZOMEWORKS TRACK RACK™ LIMITED WARRANTY

Zomeworks Corporation guarantees, to the original owner, its Track Rack™ passive solar tracker and fixed racks against defects in materials and workmanship for TEN YEARS from date of purchase. The Damping Cylinder and Bearings are warranted against defects in materials and workmanship for TWO YEARS from date of purchase.

This warranty is limited to the repair or replacement of the Track Rack™ or fixed rack in compliance with the instructions provided by Zomeworks.

Some problems can be solved with a simple on-site adjustment. Please contact Zomeworks Corporation at the address and phone number below before returning your product. You must have an RMA number to return the product for warranty repair. If possible, return only the parts that are defective or damaged. Reuse your original packing material, if it's available, or

call the factory for further instructions.

IT IS THE OWNER'S RESPONSIBILITY TO CHECK FOR DAMAGED OR MISSING PARTS IMMEDIATELY UPON RECEIPT OF THE TRACK RACK™ OR FIXED RACK. Freight claims are time sensitive and require immediate notice. If the packaging is damaged, write this on the receipt (freight bill) and have the driver initial this. Use this information to contact your freight carrier when damage is noticed.

Upon receipt of a defective part(s), freight pre-paid, Zomeworks will determine whether the defect was caused in manufacturing. If so, the part(s) will be repaired or replaced at no charge to the customer, and will be returned freight pre-paid. If the damage is not a manufacturing defect, the factory will contact the customer before any repairs are made. Original owners should contact their dealer if immediate replacement part(s) are needed. Individuals contacting Zomeworks Corporation desiring immediate replacement part will be required to provide Zomeworks Corporation with a valid credit card number to be charged for the replacement part(s). Zomeworks Corporation will credit the valid card upon receipt of the warranted returned part(s) from the individual.

This warranty does not cover rusting of the steel due to a corrosive environment (such as salt air). Standard Track Racks™ and fixed racks are painted mild steel and will require maintenance. It is the owner's responsibility to maintain the paint on the rack in order to protect the steel against corrosion. For corrosive environments, Zomeworks Corporation can manufacture the mounting racks with an epoxy primer.

Limitations on Warranty

The above ten-year and two-year warranties are the only warranties and remedies provided by Zomeworks to user. Zomeworks disclaims all implied warranties of merchantability and fitness. In no event shall Zomeworks be liable for consequential or incidental losses or damages under any theory of liability, except to the extent that this limitation is found to be unenforceable under applicable state law. Some states do not allow the exclusion or limitation of incidental or consequential damages, so this exclusion may not apply to you. This warranty gives you specific legal rights, and you may also have other rights that vary from state to state.

1011 Sawmill Rd. NW, PO Box 25805, Albuquerque, NM 87125 USA
(505) 242-5354 / (800) 279-6342 / FAX (505) 243-5187
E-mail zomework@zomeworks.com