

ZOMEWORKS

CORPORATION

FX4 POLE TOP RACK™

ASSEMBLY INSTRUCTIONS

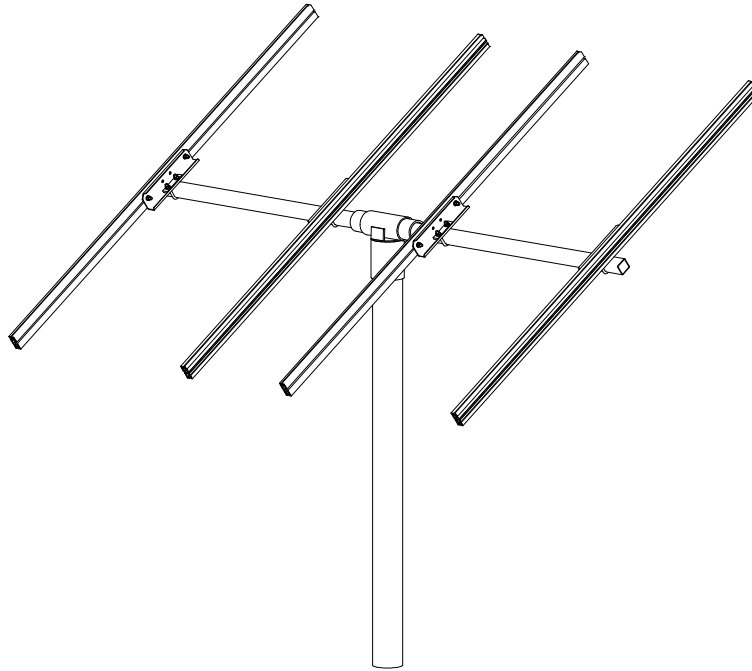

1011 Sawmill Road NW, PO Box 25805, Albuquerque, NM 87125 USA

(505) 242-5354 / (800) 279-6342 / FAX (505) 243-5187

E-mail: zomework@zomeworks.com

ZOMEWORKS FX-SERIES

Limited Warranty

Zomeworks Corporation guarantees, to the original owner, its fixed racks against defects in materials and workmanship for TEN YEARS from date of purchase. This warranty is limited to the repair or replacement of the fixed rack in compliance with the instructions provided by Zomeworks.

Some problems can be solved with a simple on site adjustment. Please contact Zomeworks Corporation at the address and phone number below before returning your product. You must have an RMA number to return the product for warranty repair. If possible, return only the parts that are defective or damaged. Reuse your original packing material, if it's available, or call the factory for further instructions.

It is the owner's responsibility to check for damaged or missing parts immediately upon receipt of the fixed rack. Freight claims are time sensitive and require immediate notice. If the packaging is damaged, write this on the receipt (freight bill) and have the driver initial this. Use this information to contact your freight carrier when damage is noticed.

Upon receipt of a defective part(s), freight pre-paid, Zomeworks will determine whether the defect was caused in manufacturing. If so, the part(s) will be repaired or replaced at no charge to the customer, and will be returned freight pre-paid. If the damage is not a manufacturing defect, the factory will contact the customer before any repairs are made. Original owners should contact their dealer if an immediate replacement part(s) are needed. Individuals contacting Zomeworks Corporation desiring immediate replacement part will be required to provide Zomeworks Corporation with a valid credit card number to be charged for the replacement part(s). Zomeworks Corporation will credit the valid credit card upon receipt of the warranted returned part(s) from the individual.

This warranty does not cover rusting of the steel due to a corrosive environment (such as salt air). Standard fixed racks are made of aluminum and painted mild steel and will require maintenance. It is the owner's responsibility to maintain the paint on the fixed rack in order to protect the steel against corrosion. For corrosive environments, Zomeworks Corporation can manufacture the fixed racks with an epoxy primer.

Limitations on Warranty

The above ten-year warranty is the only warranty and remedy provided by Zomeworks to user. Zomeworks disclaims all implied warranties of merchantability and fitness. In no event shall Zomeworks be liable for consequential or incidental losses or damages under any theory of liability, except to the extent that this limitation is found to be unenforceable under applicable state law. Some states do not allow the exclusion or limitation of incidental or consequential damages, so this exclusion may not apply to you. This warranty gives you specific legal rights, and you may also have other rights that vary from state to state.

1011 Sawmill Rd. NW, PO Box 25805, Albuquerque, NM 87125 USA
(505) 242-5354 / (800) 279-6342 / FAX (505) 243-5187
E-mail zomework@zomeworks.com

INSTRUCTIONS FOR FX4 POLE TOP RACK

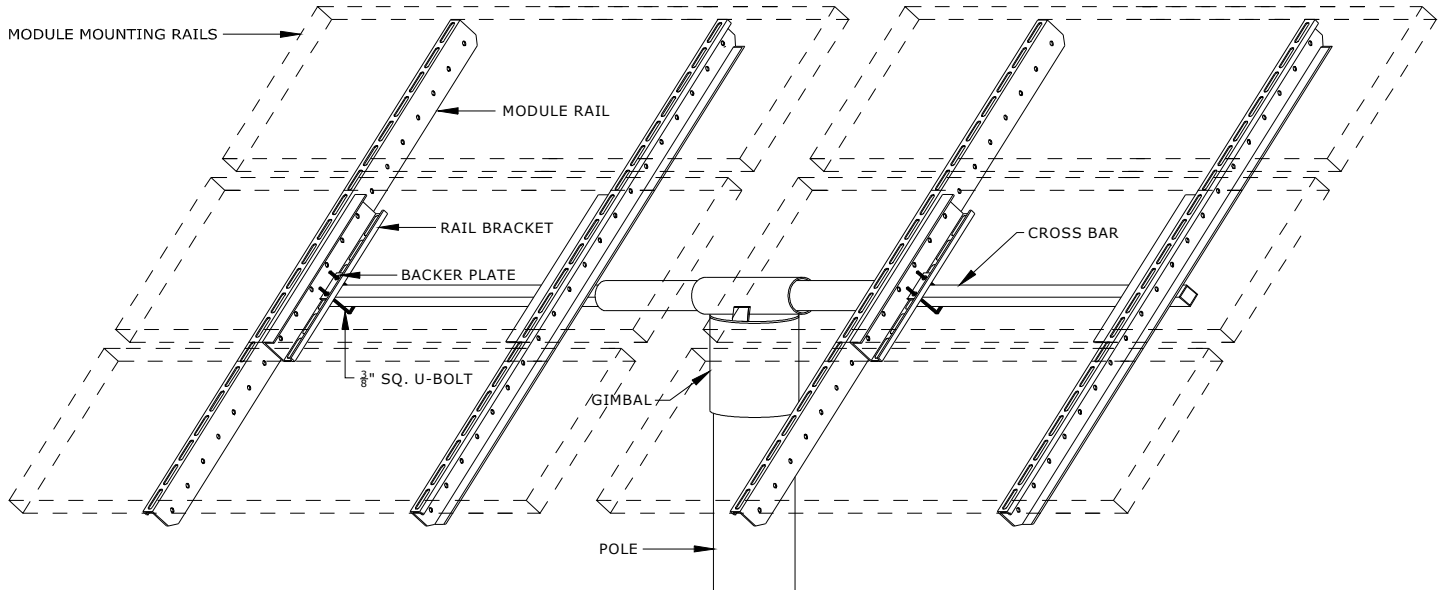

RECOMMENDED TOOLS:

- Two 9/16" and 7/16" open end, box or ratchet and socket wrenches.
- 15/16" and 3/4" wrenches.
- Tape Measure.

NOTE TO INSTALLER: Your rack may hold more modules than illustrated, but the concept is the same. Before assembling your FX4 Rack, use the list below to assure that you have all of your components. In the event that you may have missing parts, contact: **ZOMEWORKS Customer Service @ 1-800-279-6342**. Please have your Sales order number, Date of purchase, along with your Dealer name when calling. Thank you.

FX4 PARTS & HARDWARE LIST

Quantity	Description	Check
Structural Components		
1	4" Gimbal w/3 ea. 5/8" x 1 1/2" YZP Set Bolts	
1	Horizontal Cross Bar	
4	Module Mounting Rails	
4	12" long Rail bracket with U-Bolt backer plate	
Rack Assembly Hardware		
4	3/8" x 2" ZP Square U-Bolt	
8	3/8" x 1" ZP Carriage Bolt	
16	3/8" ZP Flat Washer	
16	3/8" ZP Nylock Nut	
Module hardware (X # of Modules)		
4	1/4" x 5/8" Stainless Steel Bolt	
4	1/4" Stainless Steel Hex Flange Lock Nut	

FX-SERIES POLE INSTALLATION

Important Note: ZOMEWORKS CORP. assumes no liability for the structural integrity of the pole and its installation. Soil and wind conditions vary. If there is any doubt, consult with a local Structural Engineer.

LOCATION CONSIDERATIONS:

For installations in sandy or muddy areas, for tall mounting poles, or for any mounting different from the situations described in these instructions, you will need to consult a local structural engineer. Large Racks can receive significant wind loads, so a strong mounting pole and foundation is very important. The Rack should be sited to receive maximum possible sunlight from AM to PM, Winter and Summer. Avoid shade from buildings and trees, including shade that may occur in other seasons. The height of the pole should result in adequate ground clearance for the mounted modules.

CAUTION – Be careful working around the rack after installation on the pole. Some of the structural members may be at head level.

- The customer provided pole is a minimum schedule 40 steel pipe. Pole can be black or galvanized.
Note: Heavier Steel Pipe, schedule 80, schedule 160 can also be used.
- The minimum recommended pole height above finished grade is 6 ft. At 6 ft. the largest rack will be at least 12” above grade when the rack is tilted to the maximum winter angle.
- The minimum recommended hole depth is 1/3 the pole length, (1/3 in the ground, 2/3 above the ground).
Example: 3’ below grade, 6’ above grade, total of a 9’ pole.
- The hole should be at least three times the pole diameter. Center the pipe in the hole.
- Fill the hole with concrete (3000-psi minimum strength). Check the pole for plumb with a level.
- The pole may be filled with concrete for added strength (only to approximate ground level).
- Allow concrete and pole to set for a **MINIMUM** of 36 hours **BEFORE** installing the rack.

MOUNTING POLE RECOMMENDATIONS:

Description	Model		
	FX3	FX4	FX6
Minimum Schedule 40 Steel Pipe	3" (3- $\frac{1}{2}$ " OD)	4" (4- $\frac{1}{2}$ " OD)	6" (6- $\frac{5}{8}$ " OD)
Min. Pole Height (Grade Level)	6 Feet	6 Feet	6 Feet
Min. Pole Depth (Below Grade)	3 Feet	3 Feet	3 Feet
Minimum Recommended hole diameter	12" diameter Set pipe in concrete	14" diameter Set pipe in concrete	20" diameter Set pipe in concrete

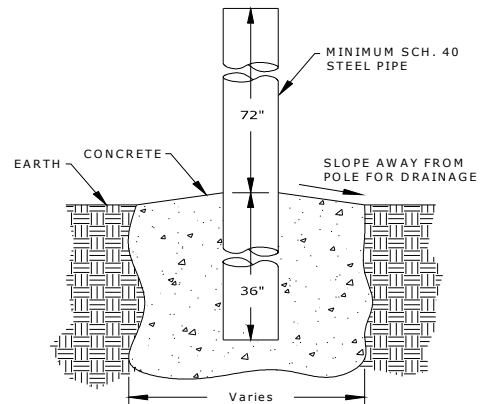

POLE INSTALLATION DETAIL

IMPORTANT NOTE: ZOMEWORKS CORP ASSUMES NO LIABILITY FOR THE STRUCTURAL INTEGRITY OF THE POLE AND ITS INSTALLATION. SOIL AND WIND CONDITIONS VARY. IF THERE IS ANY DOUBT, CONSULT WITH A LOCAL STRUCTURAL ENGINEER.

FX4 ASSEMBLY INSTRUCTIONS

Mounting Gimbal and Cross Bar:

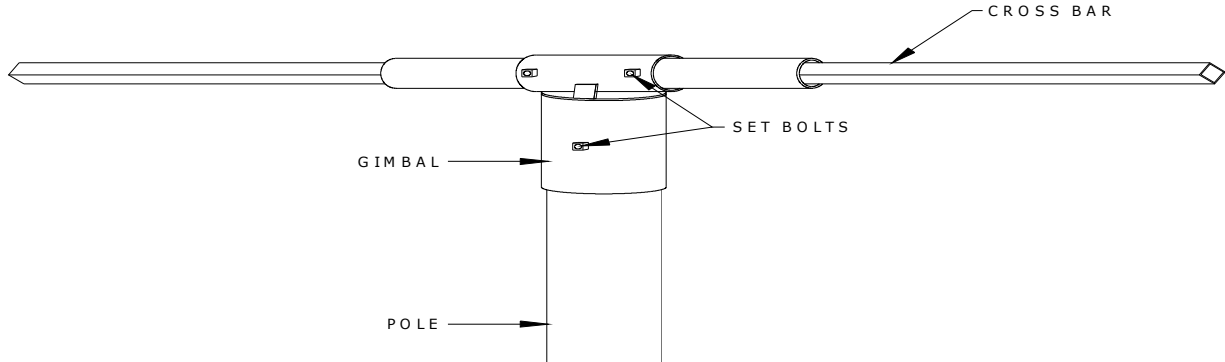

Diagram 1

- Mount Gimbal to top of Pole with Set Bolt facing due North. Secure the Gimbal Set Bolt.
- Slide Cross Bar through pipe mounted on top of Gimbal. Center and secure Set Bolts.

Mounting Module Rails:

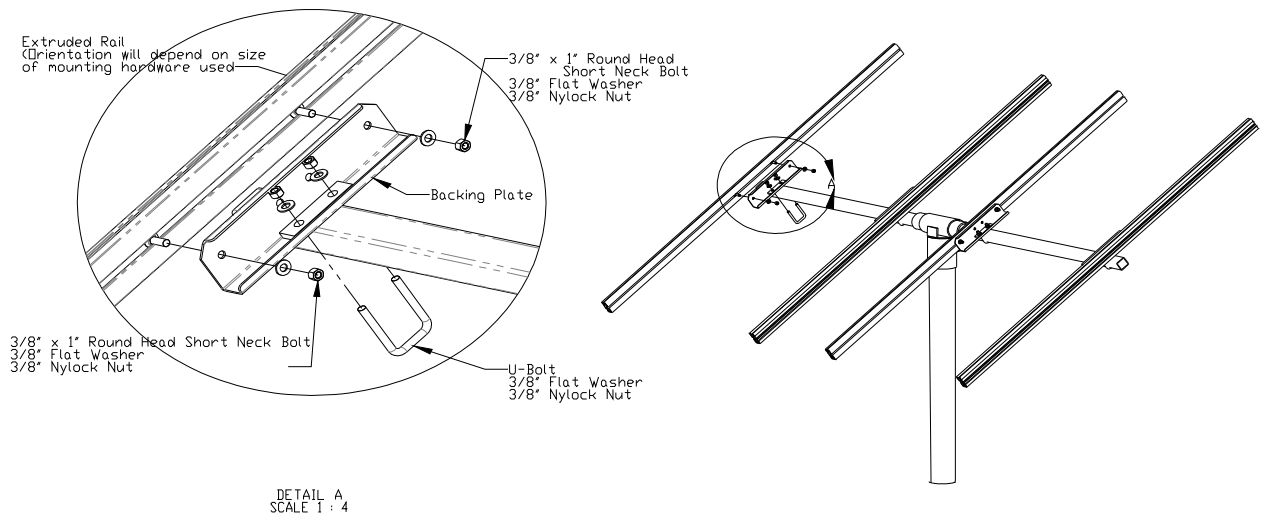

Diagram 2

- Starting at the end of the Cross Bar attach Rail Bracket with Backer Plate as shown in as shown in **Diagram 2** using (1) 3/8"x 2" ZP Sq. U-Bolt, (2) 3/8" ZP Washers and (2) 3/8" ZP Nylock Nuts.
- Center and attach Module Mounting Rails to outside holes of the Rail Brackets using (2) 3/8"x 1" ZP Carriage Bolt, (2) 3/8" ZP Washers and (2) 3/8" ZP Nylock Nuts. (The Rail Bracket and Module Rail may be pre-assembled before installation to the Cross Bar). Note that one of the slots for the module mounting hardware is sized for 1/4" hardware and that the other slot is sized for 5/16" hardware. The slot that matches the hardware you are planning to use should be on top (1/4" module mounting hardware is shipped with all of our racks).
- Adjust width of the Module Rails to fit your Modules by loosening the U-Bolts. Tighten U-Bolts securely.

Mounting Modules:

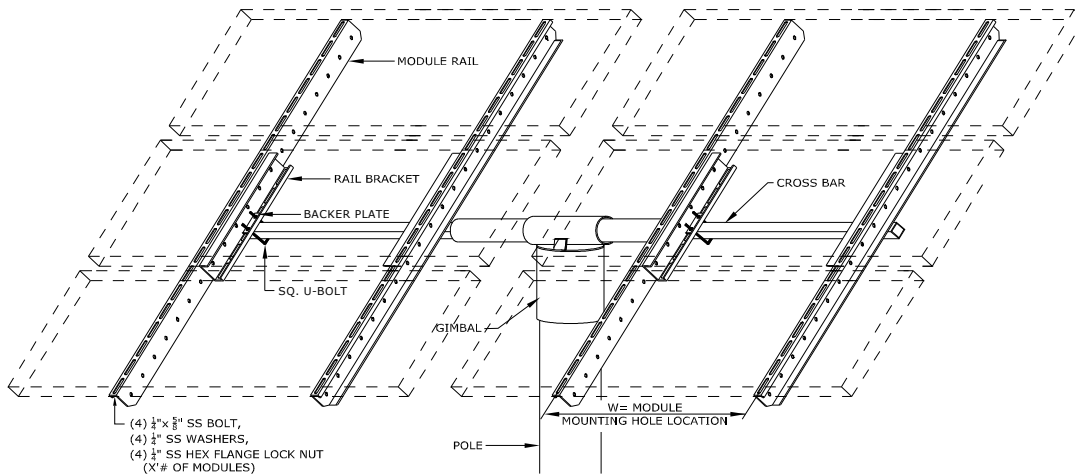

Diagram 3

- Mount each Module using (4) 1/4" x 5/8" SS Bolts and (4) 1/4" SS Hex Flange Lock Nuts
- Adjust the Modules for even spacing and tighten the Bolts.

Adjusting the Rack:

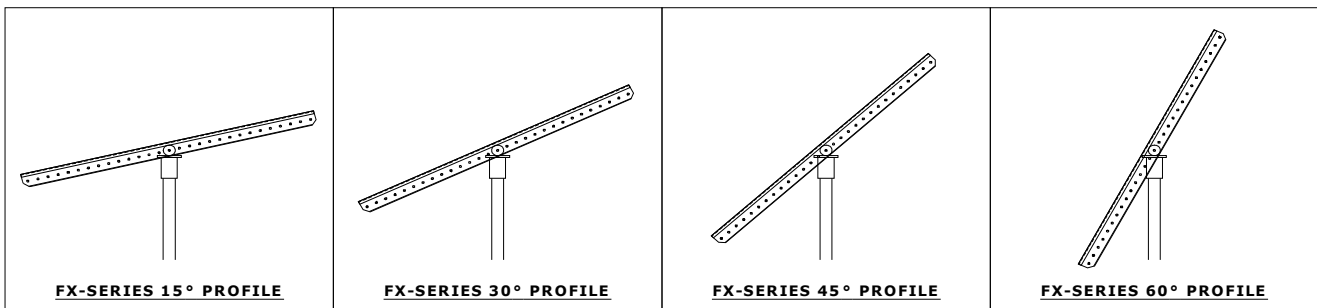

Diagram 4

- Face the Rack due South by rotating the Gimbal on the Pole. Tighten Set Bolt.
 - Loosen the Cross Bar Set Bolts.
 - Adjust tilt for maximum seasonal solar gain. Tighten the Set Bolts.
 - Check that all Bolts are tight and secure.
 - To maintain optimum performance, the Rack may be adjusted seasonally for maximum solar gain. This will vary with your location's latitude.
- Final Note:** The rack may be assembled on the ground and hoisted into position (as described in these instructions), or it may be assembled on the pole.