

# COOL CELL®

## Passive Temperature Regulating Battery Enclosures

### Installation Instructions

(Applicable to all front door models)

#### CONTENTS

1. Safety Instructions
2. General Information
3. Cool Cell® Description
4. Cool Cell® Operation
5. Site Planning and Preparation
6. Foundation
7. Lifting and placement
8. Filling
9. Cool Cell® Maintenance
10. Cool Cell® Preparation and Mounting at the Site
11. Diagrams A and B

**Read and understand these instructions completely before beginning installation. Call your supplier or Zomeworks Corporation at 505-242-5354 with any questions.**

#### 1. SAFETY INSTRUCTIONS

- A. Secure the Cool Cell® to the mounting pad before installing batteries. Extending drawers loaded with batteries can cause an unsecured Cool Cell® to tip over causing serious injury and damage.

- B. When opening the doors be certain that the windguard safety latches are fully engaged.
- C. Use only potable quality water in the cooling system. Never add antifreeze or other chemicals. They will impair Cool Cell® performance.
- D. Qualified personnel should perform Battery installation and other electrical hookups.
- E. Temperature and/or current limiting chargers are recommended. Temperature and/or current limiting safety cut-offs are also recommended.
- F. Never block or obstruct the hydrogen vent in the side of the Cool Cell®. Blockage could result in potentially explosive hydrogen concentrations developing inside the Cool Cell®.
- G. Never approach or open a Cool Cell® with an open flame or lit cigarette, cigar, etc. The cabinet should be treated as though it contains potentially explosive hydrogen.
- H. Do not move or lift the Cool Cell® loaded with batteries or water. The enclosure is not designed for these additional stresses.

## 2. GENERAL INFORMATION

- A. Installing and servicing the Cool Cell® requires only standard hand tools, except for the hexagonal allen wrench used for removing the lid fill plug. The wrench is located inside the Cool Cell® on the frame of the battery rack.
- B. Other equipment manufacturer's instructions should be referred to where applicable. They have precedence except where the Cool Cell® itself is specifically described herein.

## 3. COOL CELL® DESCRIPTION

- A. The Cool Cell® Passive Temperature Regulating Enclosure protects batteries from the extremes of heat and cold at remote outdoor sites. It can extend battery life by 200% to 400% compared to unprotected enclosures.
- B. They are constructed of 14-gauge galvanized steel, and painted with a 2-step polyurethane paint system for long term use in severe climates. The inside surfaces are insulated with 3 inches of extruded polystyrene foam. (R-15)
- C. Hinged front door access is fitted with a three-point lockable latch. Doors are fitted with safety wind guards.
- D. The passive cooling system uses no electricity. It consists of a water tank in the enclosure, plenum radiator lid, and connection hoses between the two.

- E. Battery Cool Cells® are equipped with a passive hydrogen vent designed to rid the enclosure of explosive hydrogen gas, which is generated when batteries are charged. The vent is on the right side of the enclosure near the top and is covered by a wind baffle/weather shield. The vent readily exhausts hydrogen rich air but stifles convection and unwanted heat loss or gain.

## 4. COOL CELL® OPERATION

- A. Summer Passive Cooling - The water tank is a heat sink which absorbs heat from the sun and from battery charging. At night, when ambient temperature drops, warm water within the tank rises by convection to the plenum lid and radiates heat to the cold night sky. Cool water falls to the tank below. This thermosiphoning continues throughout the night. In the morning as the lid warms, circulation stops, leaving chilled water in the tank to absorb another day of heat.
- B. Winter Freeze Protection - When water temperature falls below 39°, all circulation stops. The thermal mass of the water and the latent heat of fusion as it freezes, it protects the batteries from sub freezing temperatures for several days depending on the climate and severity of the cold spell. In cold climates, an optional heater pad (Model HTR-1) is recommended.

## 5. SITE PLANNING AND PREPARATION

- A. Avoid placing the Cool Cell® close to external heat sources.
- B. Allow for adequate workspace around the Cool Cell®, particularly in front and at the conduit openings.
- C. Access doors must have sufficient space for full 120° swing to insure the full engagement of the windguard safety latch (Refer to specs in appendix)
- D. For optimum performance, place the Cool Cell® to avoid overhanging structures that prevent a clear view of the sky.
- E. The Cool Cell® mounting surface must be level and able to support the weight of the Cool Cell®, water, and batteries. (Refer to specs in appendix)
- F. Poured-in-place concrete or pre-cast pads are recommended for mounting.

## 6. FOUNDATION

A poured in place concrete slab, concrete piers, or engineered precast concrete slab are all acceptable Cool Cell® mounting methods.

All poured in place slabs are to be a minimal 4" thick with a 6" wide turn down at the perimeter and be at least 8" deep or below the frost line which ever is greater. The concrete must be at least a 2500-psi and be reinforced with 6 x 6/ 10-10-wire mesh. The slab is to be thickened to 6" by an area of 12" x 12" at each leg. Each leg is to be bolted to the slab with a 1/2" diameter min. cast in place or drilled, anchor bolt. The enclosure must be securely attached to the foundation

to avoid cabinet tipping when battery trays are extended. The slab should extend beyond the cabinet footprint 6" on the sides and back and have a 36" apron in front for convenient access. (Refer to specs in appendix)

## 7. SETTING THE COOL CELL®

- A. Remove the dunnage and inspect the Cool Cell® for concealed shipping damage. You must immediately file any damage claims directly with the freight carrier.
- B. Check that the Cool Cell® has the following items stored inside.
  1. A funnel with a short clear vinyl hose and fitting for filling the cooling system.
  2. A hexagonal allen wrench for removing the lid plug. (Located on the battery shelf frame or tank frame).
  3. An extra O-ring lid plug seal.
  4. Bolt on ground lug.
  5. Touch-up paint.

Contact Zomeworks Corporation if any of these items are missing.

- C. **Do not install batteries or charge the cooling system with water until the enclosure is mounted and secured to the pad.**
- D. Remove the bolts holding the Cool Cell® to the pallet. Lifting ears are provided for lifting and placing the cabinet. After placement they may be left as is, removed, or turned down. Be sure to replace the bolts if the ears are moved. A forklift or a crane can be used to lift and place the Cool Cell® on the pad. Be sure that the mounting bolts

penetrate the holes of each leg sufficiently for full thread penetration and nut engagement.

- E. The Enclosure must be installed level front to back and left to right. Shim legs as required.

#### 8. CHARGING THE COOLING SYSTEM

- A. Remove the lid plug using the hex allen wrench. **Failure to remove the plug lid will prevent proper filling and will cause the system to rupture and void the warranty.**
- B. The clear vinyl hose on top of the water tank is used for filling.
- C. Several methods can be used for filling. **Use only potable quality water. Do not add antifreeze. It will prevent proper operation of the Cool Cell®.**

Funnel Method – Remove the lid plug. Connect the funnel with fitting to the water tank fill hose. Hang the funnel from the plug lid opening on the lid.

Pour water into the funnel.

Fill the water tank, hoses and plenum lid until water overflows through the lid plug.

Pressurized Tap Water Method –

Remove the lid plug. Connect a garden hose to a faucet. Use a male to male hose adapter to connect the fill hose to the garden hose.

Turn on the water and slowly fill the tank. Filling the tank too quickly could cause the system to rupture.

Flow resistance will increase as water rises through the hoses into the plenum lid. **Slow the volume.**

Continue filling until water overflows the lid.

Pump Method – A small, low pressure, 12VDC pump can be used to transfer water into the Cool Cell®.

Pump model #1P811, available from W. W.

Grainger, works well. It is low pressure (339 gph @ 1ft. head), but still has the capacity to quickly fill the system.

The pump can be fitted with a male garden hose thread fitting. A washing machine supply hose with two female hose fittings can be used to connect the pump to the fill hose on the tank. Electric extension leads to the pump fitted with alligator clips works well to connect to a 12V automotive or similar battery.

Be sure to observe correct polarity for pump operation. The pump is submersible and will transfer water from a bucket or drum.

- D. When the system is full lift the tank hose above the Cool Cell® and disconnect the end. Lower the hose to purge any air bubbles and cap the fitting. Coil the hose and stow it out of the way by the tank.
- E. After initial filling, squeeze or shake the clear vinyl hoses that connect the tank to the lid to remove air bubbles. Gently thump the roof of the Cool Cell® to dislodge any remaining air bubble. Top off the system by filling through the lid plug.

F. Replace the plug and O-Ring. Tighten to compress the seal. Store the hexagonal wrench in its holder inside the Cool Cell®. Filling is now complete.

G. Check the system for leaks.

#### 9. CONDUIT AND ELECTRICAL CONNECTION

A. Only qualified personnel should perform electrical work.

**B. The Cool Cell® must be grounded before applying any power to the unit. All Cool Cells® are provided with internal and external grounding points. (Refer to specs in appendix)**

**C.** Cable access at the Cool Cell® is through threaded female pipe fittings on either side of the enclosure. Typically, the larger fitting is for DC wiring and the smaller one for A/C accessories such as a heater. (Refer to spec sheets.)

D. Cut or drill a hole through the insulation to provide wire access. Make the hole as small as practical. The wire entrance must be sealed for safe Cool Cell® operation.

E. Minimum 2" PVC conduit is to be used below grade between the Cool Cell® and the RTU. The conduit should stub up into the RTU cable entrance chamber or other convenient location. A 2" or larger FPT entrance is provided on both sides of the Cool Cell®. (See spec sheets.) Use rigid galvanized pipe and fittings above grade to enter the cabinet. (See diagram A). After final assembly of all conduit and wiring, seal the conduit access with RTV caulk or an approved expanding foam.

This is most easily done at the LB fitting on the side of the Cool Cell®. A sealed penetration is necessary for proper and safe Cool Cell® operation.

#### Battery Wiring

F. A minimum 6 ga. Insulated stranded copper wire is to be used between the Cool Cell® and RTU. However, each individual installation must be examined to determine the specific power draw and wire requirement to maintain a minimum .20 volt drop across the battery loop. All wire must also exceed the amp rating of any circuit breaker protecting the battery system. At the Cool Cell®, be sure to leave adequate cable length for full extension of each battery tray. Use wire ties to keep battery wiring out of and away from the pullout tray slide mechanism. (See diagram B)

#### Bonding

G. 1/4" dia., 5/8" O.C. bonding studs are provided inside the Cool Cell® on the lower right side of the drawer rack. Bond this point back to the RTU cabinet. Use an insulated 6 ga. min. conductor. Connect the bond wire from the Cool Cell™ to the ground buss of the RTU cabinet.

#### Grounding

H. Double hole, 1/4" dia., 5/8" O.C. ground landings are providing at the lower right and left rear side of the Cool Cell® cabinet. Use this landing to ground the cabinet to the system "halo" ground. (6 ga. min.)

### Temperature Compensation

- I. This feature, when available should be extended to the batteries in the Cool Cell® enclosure. Most sensors require a single pair, 22 ga., shielded cable. If the sensor(s) are fitted with a modular plug, the most effective method for connection is an extension cord with matching terminations. If there are no plugs, cable may be spliced in.

### Door Alarm Switch

- J. A "pull to cheat" alarm switch is an available option. When fitted, this feature should be extended to the RTU and wired into its alarm system. Use 22 ga. shielded single pair cable. The switch can be wired for NO or NC contacts.

### Battery Installation

- K. Install and connect batteries following the manufacturer's specifications and instructions. Each pullout battery tray is designed to hold 500-lbs. maximum weight. Extend only one battery tray at a time. Maximize airspace between batteries for cooling. Always install batteries from the bottom up to maintain maximum enclosure stability.

## 10. COOL CELL® MAINTENANCE

- A. Visit the Cool Cell® 30 days after installation.
- B. Inspect the interior and exterior appearance and condition of the cabinet, including the batteries and all electrical connections. Make any adjustments as required.

- C. Use the hex allen wrench stowed, in the Cool Cell® to remove the lid plug cap and O-ring. The system may gulp some air. This is common, as the plastic tank will relax with time. If necessary, add water to the lid and fill to overflowing. If more than a quart is required, inspect the system for leaks.
- D. Replace and tighten the lid plug and stow the wrench back in its holder inside the Cool Cell®.
- E. Inspect the Cool Cell® for rust or corrosion. Any spots should be cleaned and touched up with the touch up paint provided, or with matching exterior finish paint.
- F. Inspect the hydrogen vent for physical integrity. Be sure that the filter screen is clean and unobstructed. If it is damaged, clogged, or worn, it should be fixed, cleaned, or replaced.
- G. Inspect the Cool Cell® at least once a year, preferably at the start of the cooling season. Follow the instructions outlined above. If you have any questions, contact Zomeworks Corporation, Cool Cell® Division at 1-800-279-6342.



**Diagram A**

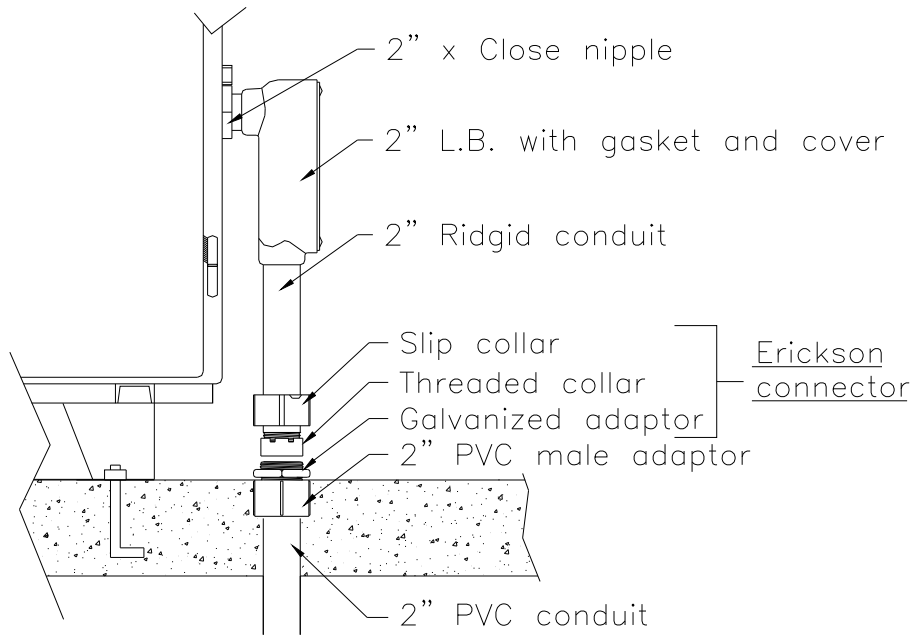

**Diagram B**

